

ET18

Tracked Conventional Tail Excavators



**WACKER
NEUSON**
all it takes!



The evolution of your working world.

Wacker Neuson sets new standards for compact excavators with its new generation of models in the 1.7 through 2.4 t class. Tried and tested innovations are retained and combined with completely new development approaches. The result: A comprehensively renewed machine class right down to the finest details, which promises greater efficiency and performance.

- Innovative, newly designed cab: The redeveloped cab of the ET range sets new standards in terms of clear layout, safety and user comfort with its completely redesigned interior.
- Powerful and efficient performance: The big diesel engines and new, innovative hydraulic system set new standards of operation.
- Maximum connection facilities with up to 4 auxiliary control circuits: Up to 4 additional control circuit options are available ex-works for all models of the ET range.
- Every ET model has its own, optimized undercarriage to guarantee maximum stability and superior drive characteristics in tough everyday conditions.

- Every ET model has its own, optimized boom system with different dipper stick lengths: Thanks to the strong boom system with a choice of two optional dipper stick lengths, every machine achieves maximum digging strength and excavation values.

ET18 Technical specifications

Operating data

Shipping weight min.	1,582 kg
Operating weight	1,725 - 2,203 kg
Biting force max.	11.2 kN
Breakout force max.	18.8 kN
Digging depth max.	2,397 mm
Digging radius max.	3,989 mm
Superstructure slewing speed	10 1/min
L x W x H	3,854 x 990 x 2,289 mm

Engine / Motor

Engine / Motor manufacturer	Yanmar
Engine / Motor type	3TNV76
Engine / Motor	Water-cooled 3-cylinder diesel engine
Displacement	1,116 cm ³
RPM / speed	2,200 rpm
Engine performance acc. to ISO	13.2 kW
Battery Voltage	44 Ah
Tank capacity	24 l

Hydraulic system

Duty pump	Double variable pump
Max. flow rate	23.8 + 23.8 l/min
Duty pump	Gear pump
Max. flow rate	19.1 + 6.5 l/min
Operating pressure for working and traction hydraulics	200 bar
Operating pressure Slewing gear	125 bar
RPM / speed Superstructure	10 rpm
Hydraulic oil tank Contents	19 l

Undercarriage

Travel speed max.	5.3 km/h
Chain width	230 mm
Ground clearance Standard undercarriage	210 mm

Dozer Blade

Width	990 mm
Height	230 mm
Stroke Standard dozer blade above ground	200 mm
Stroke Standard dozer blade below ground	320 mm

Sound level

Sound level (LwA) acc. to 2000/14/EC	93 dB(A)
Cabin - specified sound pressure level LpA acc. to ISO 6394	75.8 dB(A)

ET18 Dimensions

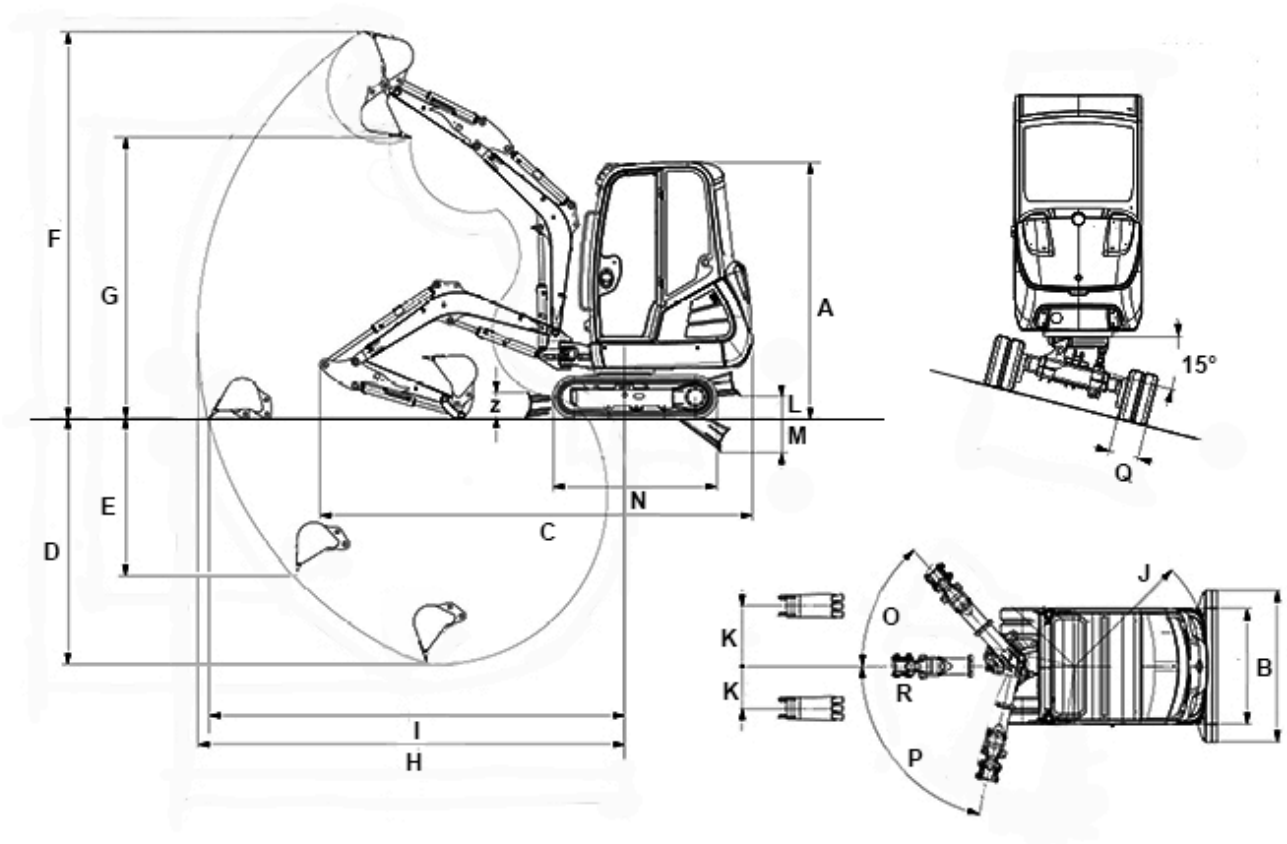

VDS

A	Height	2,285 mm	2,392 mm
B	Width Superstructure	990 mm	990 mm
B	Width undercarriage retracted	990 mm	990 mm
B	Width undercarriage extended (telescopic undercarriage only)	1,300 mm	1,300 mm
B	Width Dozer blade	990 mm	990 mm
B	Width Dozer blade width with extension (telescopic undercarriage only)	1,300 mm	1,300 mm
C	Transport length	3,854 mm	3,801 mm
D	Digging depth max. Max. (short dipper stick)	2,202 mm	2,095 mm
D	Digging depth max. Max. (long dipper stick)	2,402 mm	2,295 mm
E	Insertion depth Max., vertikal (short dipper stick)	1,415 mm	1,309 mm
E	Insertion depth Max., vertikal (long dipper stick)	1,600 mm	1,493 mm
F	Insertion height Max. (short dipper stick)	3,447 mm	3,553 mm
F	Insertion height Max. (long dipper stick)	3,558 mm	3,663 mm
G	Dump height max. Max. (short dipper stick)	2,510 mm	2,611 mm
G	Dump height max. Max. (long dipper stick)	2,621 mm	2,722 mm
H	Digging radius max. Max. (short dipper stick)	3,802 mm	3,802 mm
H	Digging radius max. Max. (long dipper stick)	3,989 mm	3,989 mm

I	Range Max. ,on the ground (short dipper stick)	3,700 mm	3,668 mm
I	Range Max. ,on the ground (long dipper stick)	3,894 mm	3,864 mm
J	Rear swivel radius Min.	1,169 mm	1,169 mm
K	Arm displacement Max. , to centre of bucket, right side	516 mm	516 mm
K	Arm displacement Max. , to centre of bucket, left side	359 mm	359 mm
L	Lift height Max., of dozer blade above ground (short)	198 mm	268 mm
L	Lift height Max., of dozer blade above ground (long)	281 mm	357 mm
M	Scraping depth Max., of dozer blade below ground (short)	316 mm	251 mm
M	Scraping depth Max., of dozer blade below ground (long)	381 mm	308 mm
N	Length Total crawler length (standard undercarriage)	1,462 mm	1,465 mm
N	Length Total crawler length (telescopic undercarriage)	1,607 mm	1,607 mm
--	Length Crawler length Sprocket wheel (standard undercarriage)	1,080 mm	1,079 mm
--	Length Crawler length Sprocket wheel (telescopic undercarriage)	1,225 mm	1,224 mm
O	Turning angle Max. of boom system to the right	48 °	48 °
P	Turning angle Max. of boom system to the left	77 °	77 °
Q	Chain width	230 mm	230 mm
R	Boom slewing radius centre	1,584 mm	1,584 mm
--	Boom slewing radius right	1,503 mm	1,503 mm
--	Boom slewing radius left max.	1,283 mm	1,283 mm
--	Boom slewing radius left lock	1,374 mm	1,374 mm
Z	Height Dozer blade	230 mm	230 mm

Please note: that product availability can vary from country to country. It is possible that information / products may not be available in your country. More detailed information on engine power can be found in the operator's manual; the stated power may vary due to specific operating conditions. Subject to alterations and errors excepted. Applicable also to illustrations.
Copyright © 2019 Wacker Neuson SE.